

XA CONNECTOR

Disconnectable Crimp style connectors

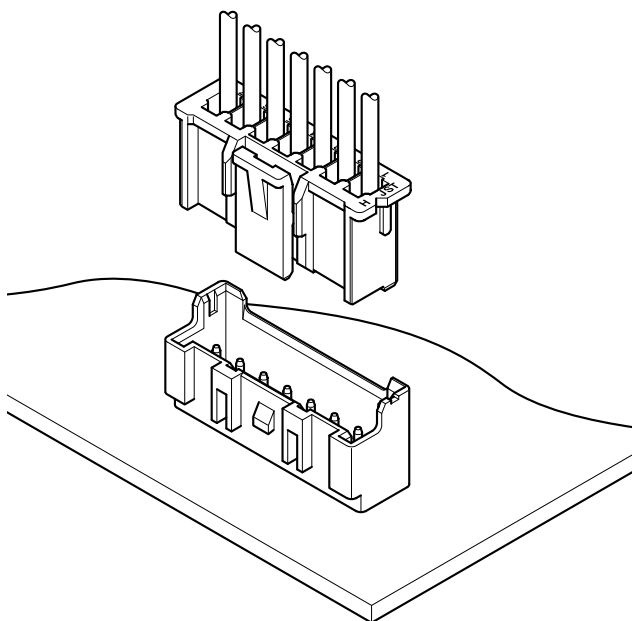
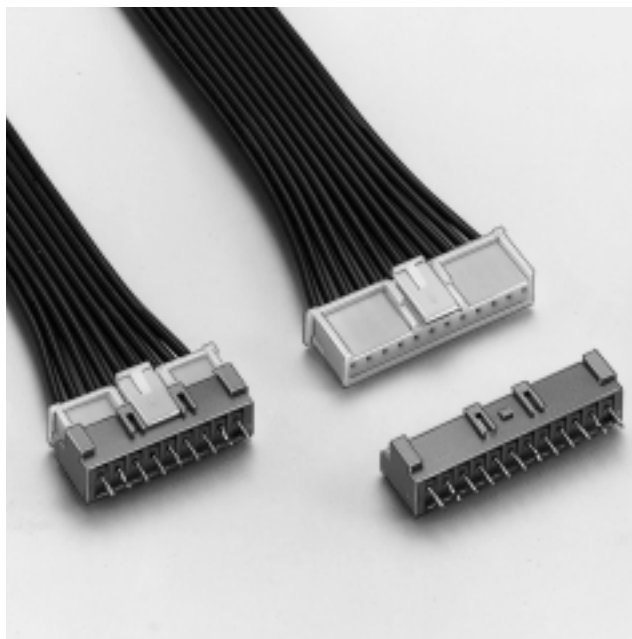
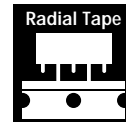

Features

• Locking device

The housing has a locking device to securely hold the header, preventing accidental disconnection because of external forces that might result from the routing of wires during assembly process or of vibration.

• Solder crack preventive material

Header wafer is made of glass-filled PA66 nylon thus effective against the solder crack problem.

• Low insertion force

Header pins are round and reflow-treated, which provides low insertion force.

• Insertion guide mechanism

Header has housing insertion guides for easy and secure insertion.

• Applicable to automatic board mounting machine

Radial taped or stick-mounted headers are also available for automatic component insertion machine.

• Polarizing boss

Headers with polarizing bosses are also available.

Specifications

- Current rating: 3A AC DC (AWG#20)
 - Voltage rating: 250V AC DC
 - Temperature range: -25°C to +85°C
(including temperature rise in applying electrical current)
 - Relative humidity: 0 to 80%
 - Contact resistance: Initial value/10m Ω max.
After environmental testing/20m Ω max.
 - Insulation resistance: 1,000M Ω min.
 - Withstanding voltage: AC 1,000V/minute
 - Applicable wire: AWG #28 to #20
 - Applicable PC board thickness: 1.6mm (.063")
- * Contact JST for details.

Standards

- Recognized E60389
- 1 Certified LR20812
- 2 R9851220

XA CONNECTOR

Contact

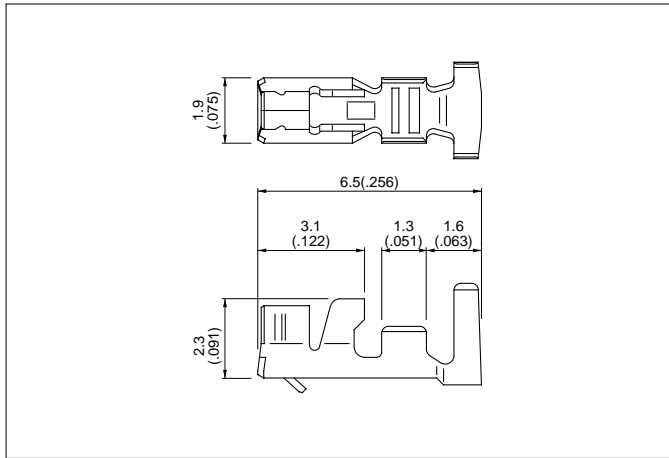

Model No.	Applicable wire			Q'ty / reel
	mm ²	AWG#	Insulation O.D. mm(in.)	
SXA-001T-P0.6	0.08 to 0.33	28 to 22	1.2 to 1.9(.047 to .075)	8,000
SXA- 01T-P0.6	0.22 to 0.5	24 to 20	1.5 to 1.9(.059 to .075)	8,000
SXA-001T-P0.6L	0.13 to 0.33	26 to 22	1.3 to 1.7(.051 to .067)	8,000

Material and Finish

Phosphor bronze, tin-plated

Housing

<Standard type>

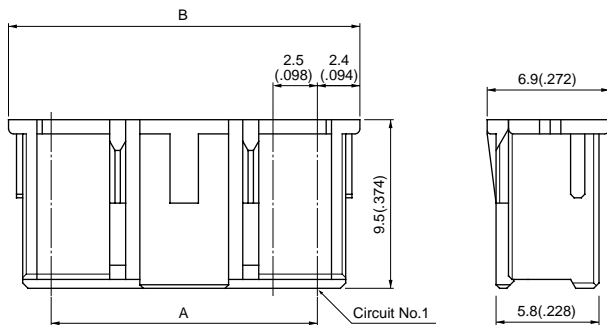

<Retainer mountable type>

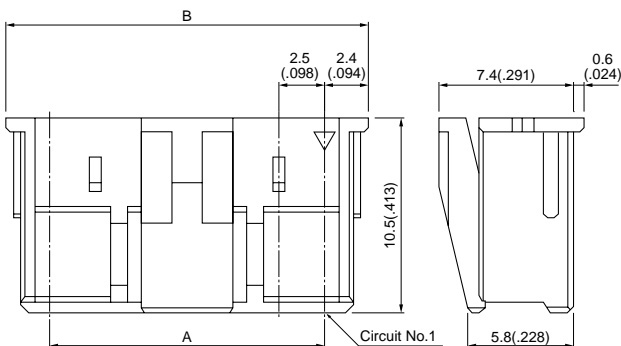

Cir- cuits	Model No.		Dimensions mm(in.)		Q'ty / bag	
	Standard type	Retainer mountable type	A	B	Standard type	Retainer mountable type
2	XAP-02V-1	XARP-02V	2.5(.098)	7.3(.287)	1,000	1,000
3	XAP-03V-1	XARP-03V	5.0(.197)	9.8(.386)	1,000	1,000
4	XAP-04V-1	XARP-04V	7.5(.295)	12.3(.484)	1,000	1,000
5	XAP-05V-1	XARP-05V	10.0(.394)	14.8(.583)	1,000	1,000
6	XAP-06V-1	XARP-06V	12.5(.492)	17.3(.681)	1,000	1,000
7	XAP-07V-1	XARP-07V	15.0(.591)	19.8(.780)	1,000	1,000
8	XAP-08V-1	XARP-08V	17.5(.689)	22.3(.878)	1,000	1,000
9	XAP-09V-1	XARP-09V	20.0(.787)	24.8(.976)	1,000	1,000
10	XAP-10V-1	XARP-10V	22.5(.886)	27.3(1.075)	1,000	1,000
11	XAP-11V-1	XARP-11V	25.0(.984)	29.8(1.173)	1,000	1,000
12	XAP-12V-1	XARP-12V	27.5(1.083)	32.3(1.272)	1,000	1,000
13	XAP-13V-1	XARP-13V	30.0(1.181)	34.8(1.370)	1,000	1,000
14	XAP-14V-1	XARP-14V	32.5(1.280)	37.3(1.469)	500	1,000
15	XAP-15V-1	XARP-15V	35.0(1.378)	39.8(1.567)	500	1,000
20	XAP-20V-1	—	47.5(1.870)	52.3(2.059)	500	—

Material

Nylon 66, UL94V-0, natural (white)

Retainer

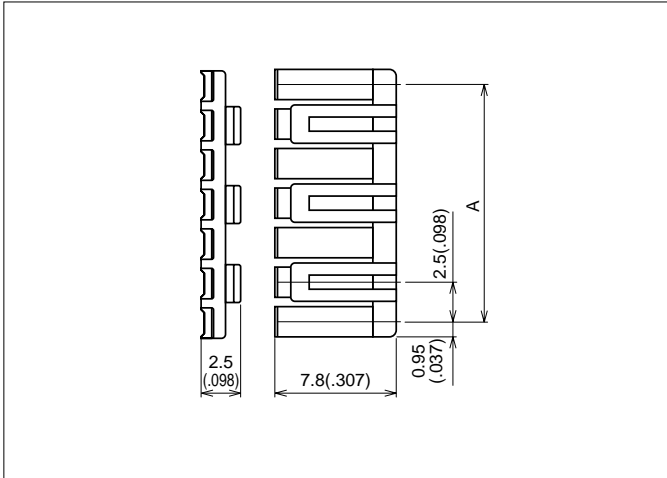

Circuits	Model No.	A	Q'ty / bag
2	XMS-02V	2.5(.098)	1,000
3	XMS-03V	5.0(.197)	1,000
4	XMS-04V	7.5(.295)	1,000
5	XMS-05V	10.0(.394)	1,000
6	XMS-06V	12.5(.492)	1,000
7	XMS-07V	15.0(.591)	1,000
8	XMS-08V	17.5(.689)	1,000
9	XMS-09V	20.0(.787)	1,000
10	XMS-10V	22.5(.886)	1,000
11	XMS-11V	25.0(.984)	1,000
12	XMS-12V	27.5(1.083)	1,000
13	XMS-13V	30.0(1.181)	1,000
14	XMS-14V	32.5(1.280)	1,000
15	XMS-15V	35.0(1.378)	1,000

Material

Glass-filled nylon 66, UL94V-0, natural (ivory)

XA CONNECTOR

Through-hole type shrouded header

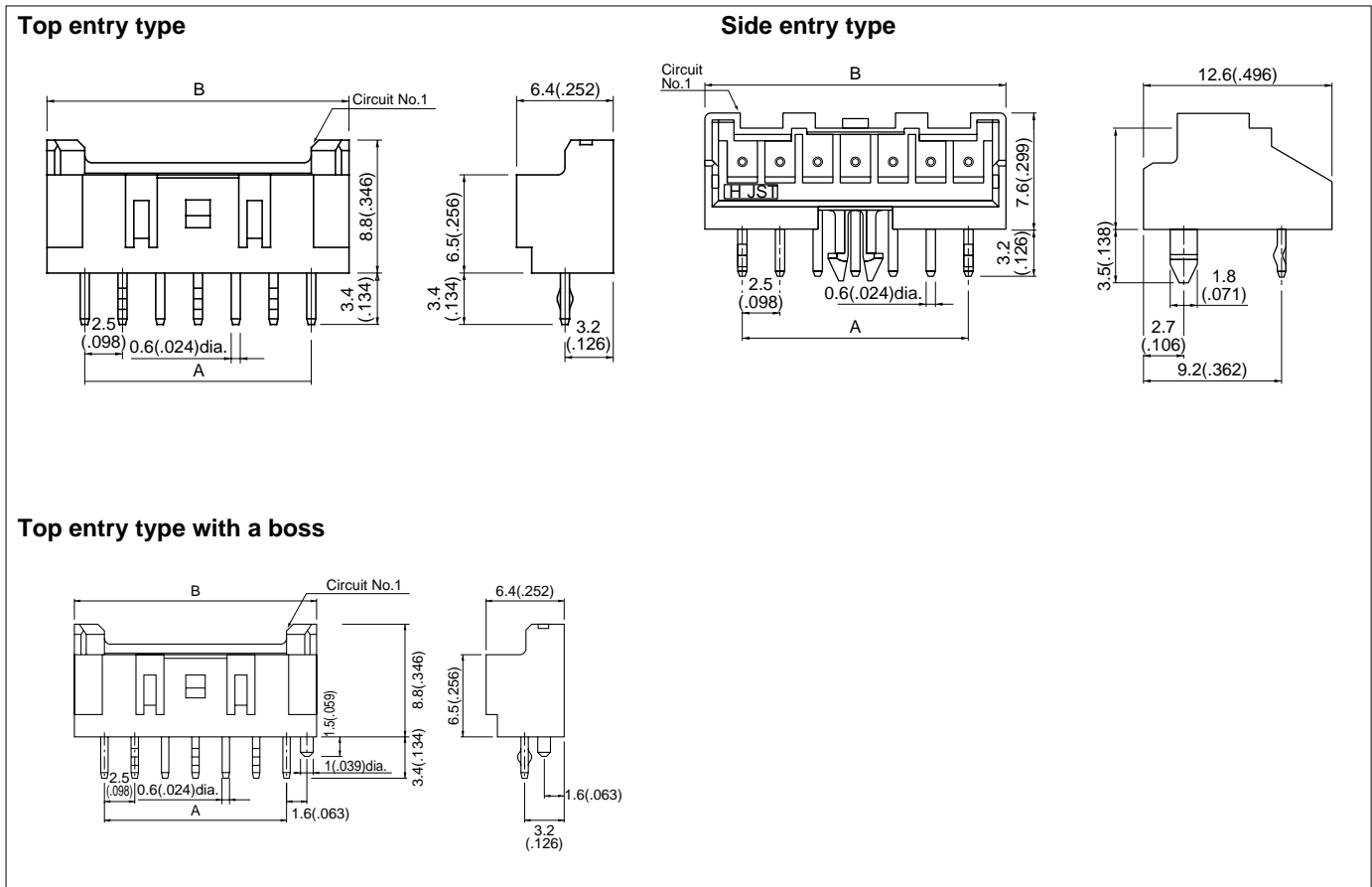

Circuits	Model No.			Dimensions mm(in.)			Q'ty / box		
	Top entry type		Side entry type	A	B	D	Top entry type		Side entry type
	Without a boss	With a boss					Without a boss	With a boss	
2	B02B-XASK-1	B02B-XASK-1-A	S02B-XASS-1	2.5 (.098)	7.5 (.295)	1.25 (.049)	1,000	1,000	—
3	B03B-XASK-1	B03B-XASK-1-A	S03B-XASK-1	5.0 (.197)	10.0 (.394)	2.5 (.098)	400	400	250
4	B04B-XASK-1	B04B-XASK-1-A	S04B-XASK-1	7.5 (.295)	12.5 (.492)	3.75 (.148)	400	400	200
5	B05B-XASK-1	B05B-XASK-1-A	S05B-XASK-1	10.0 (.394)	15.0 (.591)	5.0 (.197)	400	400	200
6	B06B-XASK-1	B06B-XASK-1-A	S06B-XASK-1	12.5 (.492)	17.5 (.689)	6.25 (.246)	400	400	200
7	B07B-XASK-1	B07B-XASK-1-A	S07B-XASK-1	15.0 (.591)	20.0 (.787)	7.50 (.295)	400	400	200
8	B08B-XASK-1	B08B-XASK-1-A	S08B-XASK-1	17.5 (.689)	22.5 (.886)	8.75 (.344)	250	250	100
9	B09B-XASK-1	B09B-XASK-1-A	S09B-XASK-1	20.0 (.787)	25.0 (.984)	10.00 (.394)	250	250	100
10	B10B-XASK-1	B10B-XASK-1-A	S10B-XASK-1	22.5 (.886)	27.5 (1.083)	11.25 (.443)	250	250	100
11	B11B-XASK-1	B11B-XASK-1-A	S11B-XASK-1	25.0 (.984)	30.0 (1.181)	12.50 (.492)	250	250	100
12	B12B-XASK-1	B12B-XASK-1-A	S12B-XASK-1	27.5 (1.083)	32.5 (1.280)	13.75 (.541)	200	200	100
13	B13B-XASK-1	B13B-XASK-1-A	S13B-XASK-1	30.0 (1.181)	35.0 (1.378)	15.00 (.591)	200	200	100
14	B14B-XASK-1	B14B-XASK-1-A	S14B-XASK-1	32.5 (1.280)	37.5 (1.476)	16.25 (.640)	100	100	100
15	B15B-XASK-1	B15B-XASK-1-A	—	35.0 (1.378)	40.0 (1.575)	—	100	100	—
20	B20B-XASK-1	—	—	47.5 (1.870)	52.5 (2.067)	—	100	—	—

Material and Finish

Pin: Copper alloy, Copper-undercoated, tin/lead plated
 Wafer: Glass-filled nylon 66, UL94V-0, natural (ivory)

Note: Dimension D... See PC board layout.

Through-hole type shrouded header on radial-tape

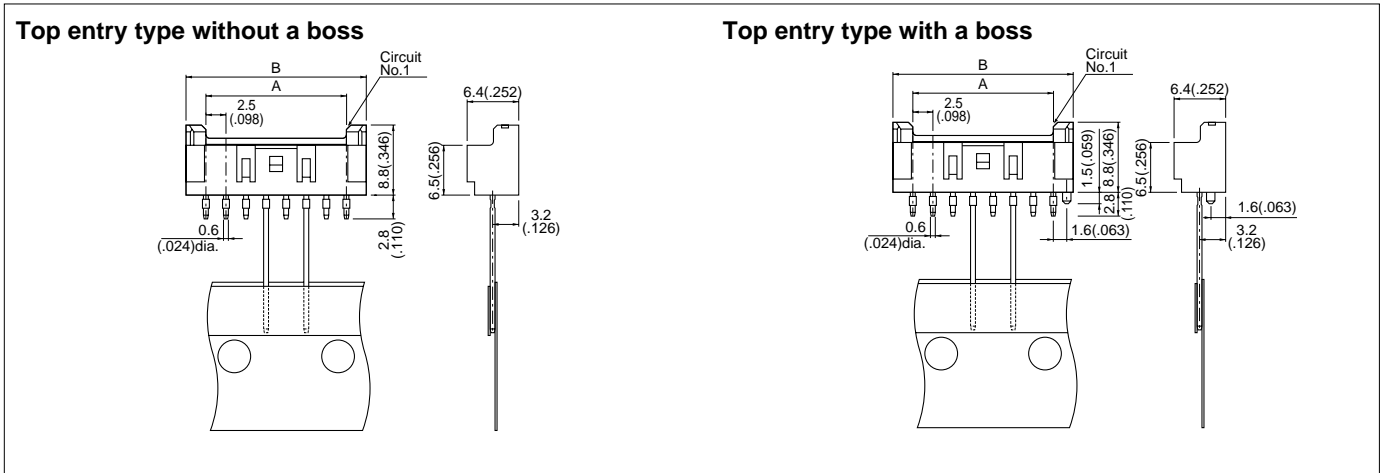

Circuits	Model No.		Dimensions mm(in.)		Q'ty / box
	Top entry type without a boss	Top entry type with a boss	A	B	
2	B02B-XASS-1-T	—	2.5(.098)	7.5(.295)	1,000
3	B03B-XASS-1-T	B03B-XASS-1-A-T	5.0(.197)	10.0(.394)	1,000
4	B04B-XASS-1-T	B04B-XASS-1-A-T	7.5(.295)	12.5(.492)	500
5	B05B-XASS-1-T	B05B-XASS-1-A-T	10.0(.394)	15.0(.591)	500
6	B06B-XASS-1-T	B06B-XASS-1-A-T	12.5(.492)	17.5(.689)	500
7	B07B-XASS-1-T	B07B-XASS-1-A-T	15.0(.591)	20.0(.787)	500
8	B08B-XASS-1-T	B08B-XASS-1-A-T	17.5(.689)	22.5(.886)	500

Material and Finish

Pin: Copper alloy, Copper-undercoated, tin/lead plated
 Wafer: Glass-filled nylon 66, UL94V-0, natural (ivory)

Taping specifications of through-hole type shrouded header

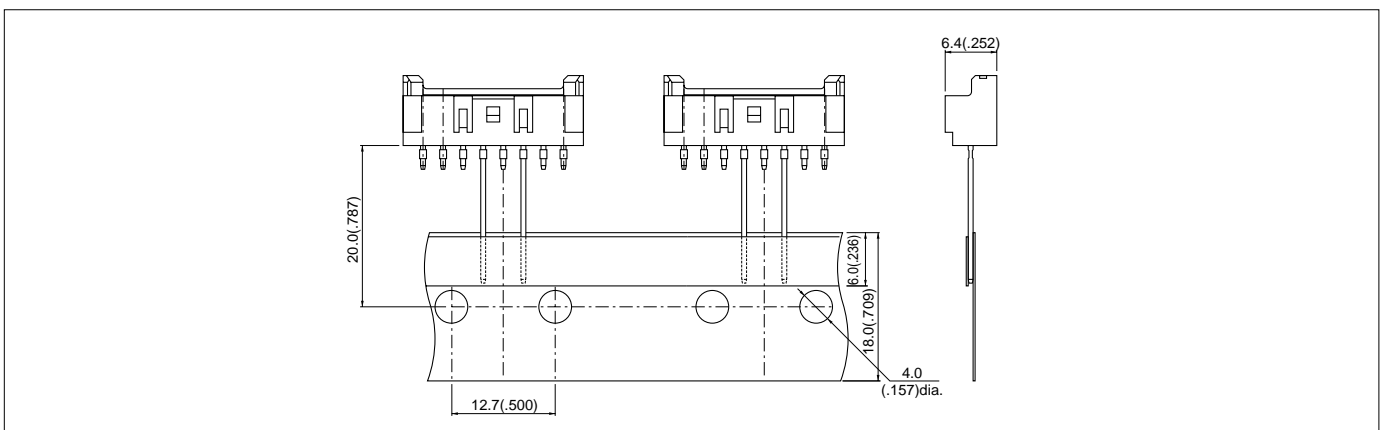

XA CONNECTOR

Packaging specifications of through-hole type shrouded header

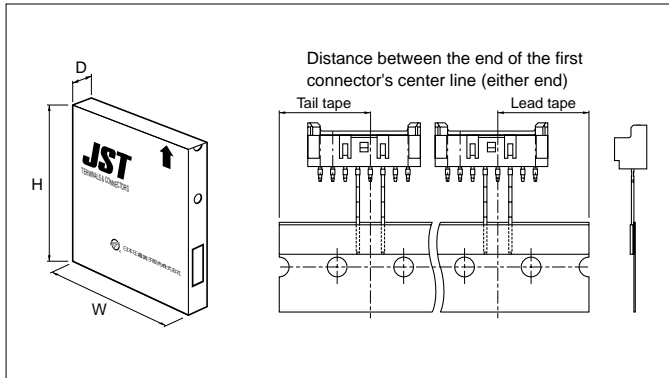

Package type	Flat pack (zigzag folded)
Distance between folds	24 indexing holes per fold (304.8mm/12")
Box size	(316 X 45 X 330mm) 12.4"(W) X 1.8"(D) X 13.0"(H)
Distance between the end of the tape and the first connector's center line (either end)	19.05mm(.750")

Products of different packaging specifications are also available.
Contact JST for details.

Through-hole type PC board layout (viewed from component side) and Assembly layout

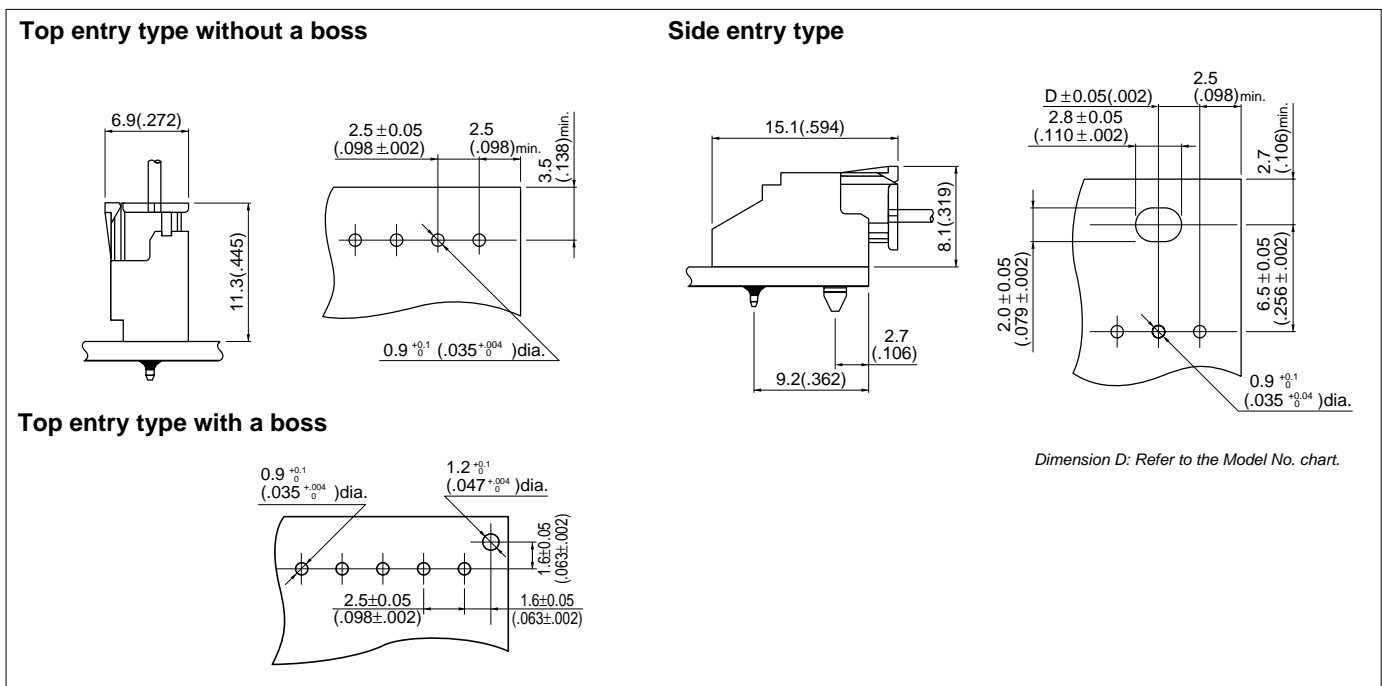

Note:

1. Tolerances are non-Cumulative: $\pm 0.05\text{mm} (\pm .002")$ for all centers.
2. Hole dimensions differ according to the kind of PC board and piercing method.
The dimensions above should serve as a guide line. Contact JST for details.

SMT type shrouded header

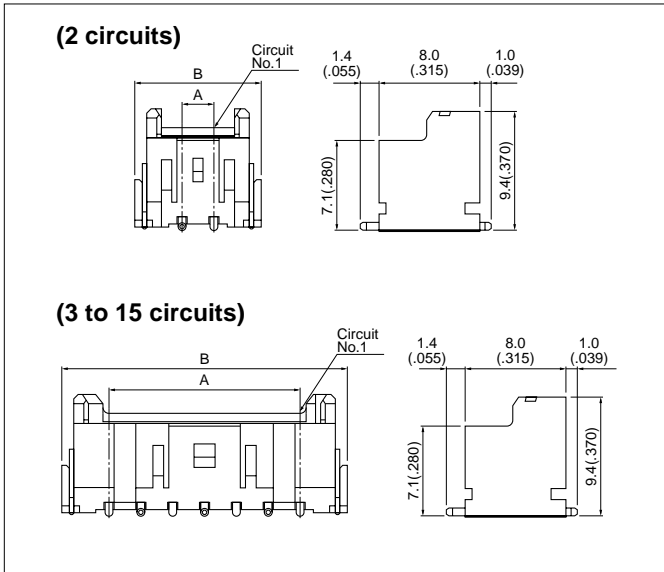

Circuits	Model No.	Dimensions mm(in.)		Q'ty / reel
		Top entry type	A	
2	BM02B-XASS-TF	2.5(.098)	10.0(.394)	500
3	BM03B-XASS-TF	5.0(.197)	12.5(.492)	500
5	BM05B-XASS-TF	10.0(.394)	17.5(.689)	500
6	BM06B-XASS-TF	12.5(.492)	20.0(.787)	500
7	BM07B-XASS-TF	15.0(.591)	22.5(.886)	500
8	BM08B-XASS-TF	17.5(.689)	25.0(.984)	500
9	BM09B-XASS-TF	20.0(.787)	27.5(1.083)	500
12	BM12B-XASS-TF	27.5(1.083)	35.0(1.378)	500
13	BM13B-XASS-TF	30.0(1.181)	37.5(1.476)	500
15	BM15B-XASS-TF	35.0(1.378)	42.5(1.673)	500

Material and Finish

Pin: Copper alloy, copper-undercoated, tin/lead-plated
 Wafer: Polyamide resin, UL94V-0, natural (ivory)
 Solder tab: Brass, copper-undercoated, tin/lead-plated

Note: The products listed above are supplied on embossed tape.

Taping specifications of SMT type shrouded headers

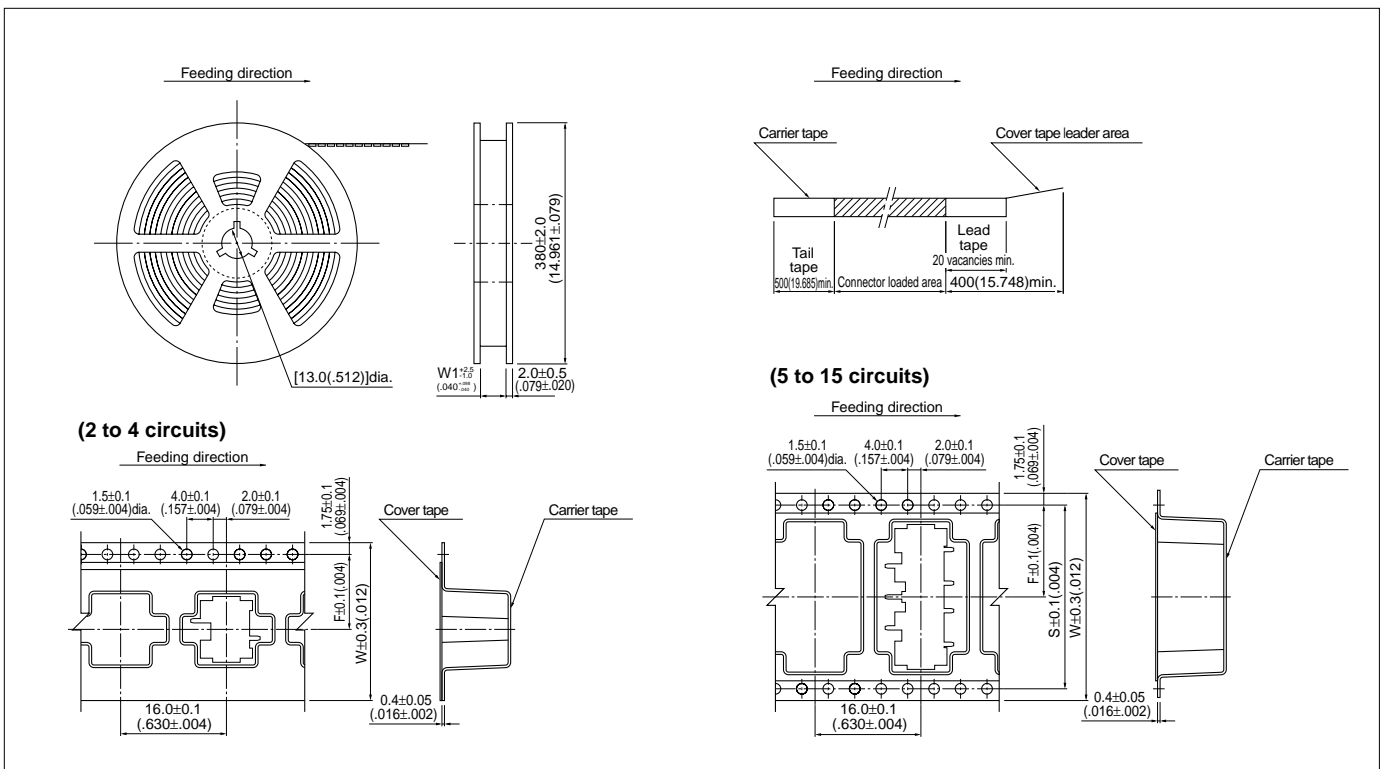

Note:

- Specifications conform to JIS C 0806. The tape width, connector recess dimensions, etc. are determined by the number of circuits and external shape of the connector to be loaded.
- Specifications are subject to change without prior notice.

Circuits	Taping dimensions mm(in.)			Reel dimensions mm(in.)	Q'ty / reel
	F	S	W		
2 to 3	11.5(.453)	—	24.0(.945)	25.5(1.004)	500
5	14.2(.559)	28.4(1.118)	32.0(1.260)	33.5(1.319)	500
6 to 10	20.2(.795)	40.4(1.591)	44.0(1.732)	45.5(1.791)	500
12 to 15	26.2(1.031)	52.4(2.063)	56.0(2.205)	57.5(2.264)	500

XA CONNECTOR

SMT type PC board layout (viewed from component side) and Assembly layout

Top entry type

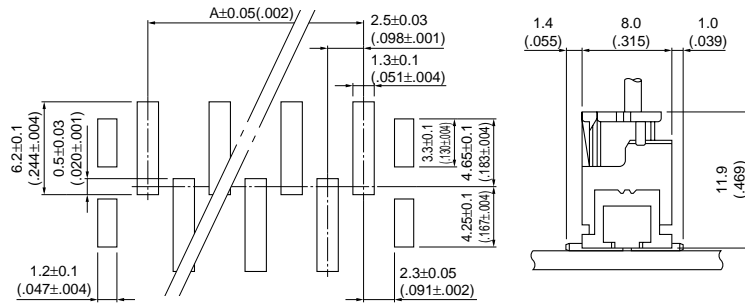

Note:

1. Tolerances are non-Cumulative: $\pm 0.05\text{mm} (\pm .002")$ for all centers.
2. Hole dimensions differ according to the kind of PC board and piercing method.
The dimensions above should serve as a guide line. Contact JST for details.